

# MCP 5000

MCP 5000 Automatic linear capping machine, designed for the chemical industry and the food sector. Made of stainless steel with a polycarbonate protective screen.

Thanks to its cap lifter, loading is done quickly and easily.

With a robust and versatile design for the placement and closing of caps. Controlled by a 4.5" touch screen that is easy to use for adjusting the different parameters.

Minimal maintenance with easily removable guards and accessibility to all elements of the machine.

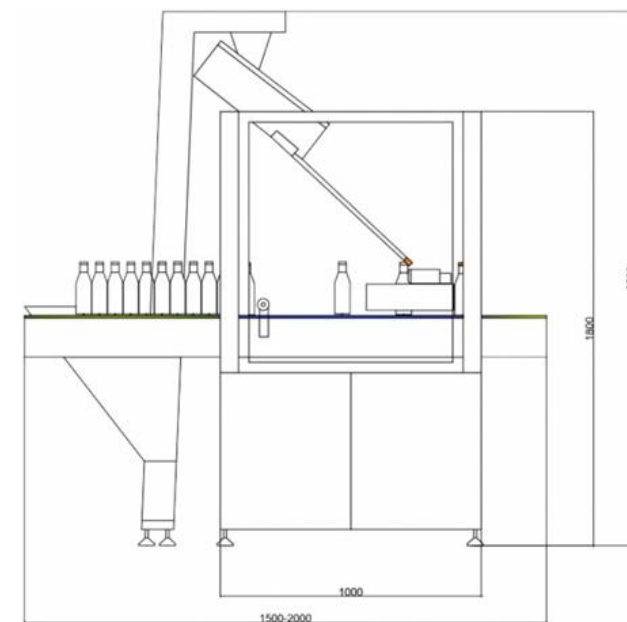
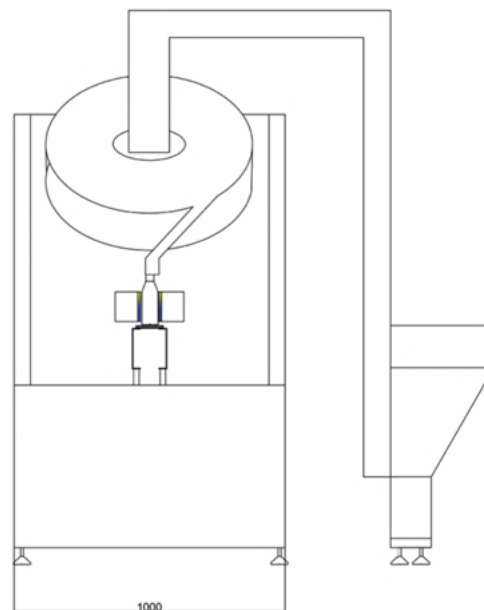

## CHARACTERISTICS

**Speed:** 3.500 containers/hour by pressure; 2.000 containers/hour screw cap.

**Type of plug:** Thread or Pressure.

**Fastening:** Side bands with independent gear motor.

**Head:** Thread or pressure, motorized or pneumatic depending on formats.

**Positioner:** Star motorized rotary.

**Feeder:** Medium according to caps or lid with 800 mm hopper.

**Screen:** Touch screen with recipes for easy format changes.

## OPTIONAL:

- **Transport and positioning of the plug** consisting of a swan neck cap elevator, with hopper and standard controlled motor.

MARCOPACK, S.L. - P.I. Saladar II - Calle 2, Manzana 38-6 • 30564 Lorquí (Murcia) Spain • Tlf.: +34 968 692 265 - Mobile: +34 674 147 272  
www.marcopack.com - E-mail: [marcopack@marcopack.com](mailto:marcopack@marcopack.com)

Marcopack reserves the right to modify the design and specifications of this machinery, as it is a product in continuous development.

